

WARM ROOF – WALKABLE, CLASSICAL STRUCTURE, BITUMEN SHEET WATERPROOFING
PAVEMENT IN SAND SUBBASE

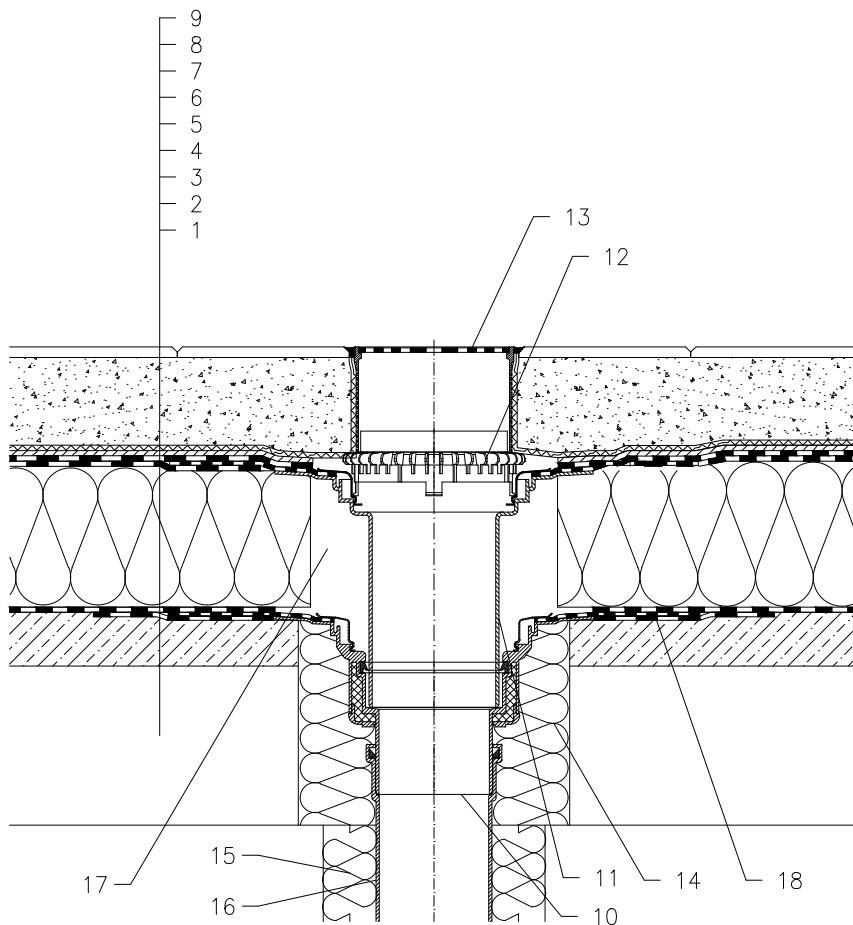

- 1 SUPPORT CONSTRUCTION
- 2 GRAVITY LAYER
- 3 MOISTURE STOP AND TEMPORARY SAFETY WATERPROOFING FROM BITUMEN SHEET
- 4 THERMAL INSULATION
- 5 BITUMEN SHEET WATERPROOFING NON-SOLID GLUED OR LAID LOOSE
- 6 DRAINAGE LAYER
- 7 FILTER LAYER
- 8 SAND SUBBASE
- 9 PAVEMENT
- 10 FLAT-ROOF DRAIN HL62BH WITH INSULATED DRAIN BODY, WITH FACTORY WELDED BITUMEN MEMBRANE ϕ 500 mm, THICKNESS 4 mm
- 11 EXTENSION HL65H WITH FLANGE AND FACTORY WELDED BITUMEN MEMBRANE ϕ 500 mm, THICKNESS 4 mm
- 12 GRAVEL GUARD HL160
- 13 GRATING HL66.9 WITH STAINLESS STEEL GRATE 150x150 mm CHARGEABLE TO 300 kg (INCL. WITH HL62BH)
- 14 ASSEMBLY FOAM
- 15 DOWNPIPE THERMAL INSULATION
- 16 DOWNPIPE
- 17 FILL FREE SPACE WITH MINERAL WOOL
- 18 BITUMEN MEMBRANE, ϕ 750 mm

NOTE:

FLAT-ROOF DRAIN HL62.1BH HEATED (230V, 10-30 WATTS) CAN BE USED.

ASSEMBLY INLET: ϕ 255 mm, OR 255 x 380 mm

122121A